



Material Selection & Corrosion Management

For Oil & Gas and Industrial Plants at Design Stage



Material Selection in Oil & Gas and Energy Industry

Oil and gas production industry (Fig. 1) is facing increasingly severe corrosion problems, caused by contaminants like CO_2 and H_2S or salty water, in combination with extreme operating conditions in terms of temperature, pressure, flow velocity and mechanical solicitations.

Similar problems are faced by the energy industry in general where industrial plants, refineries and chemical plants require a greater flexibility to handle a wider range of fluids.

The occurrence of corrosion events is known to have significant economic impacts on production, and above all social consequences concerning health, safety and environmental issues.

Material selection provides a key contribution to asset integrity in a sustainable perspective.



Fig. 1 - Oil and gas treatment plant

Material Selection & Industrial Facilities

Corrosion threats are seen along both onshore and offshore production and industrial facilities (Fig. 2-5), including:

- Oil & gas production and injection wells
- Flow- and trunk-line networks
- Oil & gas treatment plants
- Storage tanks
- Export pipelines and delivery pumps
- Floating Production Storage and Offloading - FPSO
- Refineries
- Chemical & petrochemical plants
- Industrial plants (desalination plants, waste water treatment plants, etc.).



Fig. 2 - Oil storage tanks



Fig. 3 - Petrochemical plant



Fig. 4 - Crude export pipeline



Fig. 5 - Offshore wind farm

The Material Selection Tasks

The material selection task is accomplished through the following steps:

- Fluid corrosivity evaluation based on fluid characteristics and operating conditions
- Definition of chemical injection philosophy
- Definition of most suitable materials for each component
- Identification of proper corrosion control methods
- Additional requirements for sour service, low temperature and welding
- Requirements for selection and qualification of corrosion inhibitors (laboratory and field-testing)
- Requirements for external corrosion protection with coatings and cathodic protection systems
- Requirements for internal corrosion monitoring
- Requirements for internal and external corrosion inspections.

Material Selection is carried out in conformity with International Normative (ISO, DNV, API, NACE, Norsok) and with major Company Standards and Project related technical specifications.

Corrosion & Material Selection Deliverables

During the Design Phase of a project, CESCOR can provide assistance for the following task activities and relevant deliverables:

- Corrosion and Materials Selection Reports (MSR)
- Material Selection Diagrams (MSD)
- Chemical Treatments Philosophy
- Corrosion Monitoring Design Reports (CMR)
- Painting and Coating Specifications
- Corrosion Management Manuals (CMM).

Material Selection Diagrams

Material Selection Diagrams (MSD) graphically show the selected material for each component (piping and pressure equipment) (Fig. 6-7). Other useful data reported in the MSD are:

- Corrosion control methods
- Low temperature and sour service requirements
- Location of chemical injection points
- Location of corrosion probes and coupons
- Specification breaks.

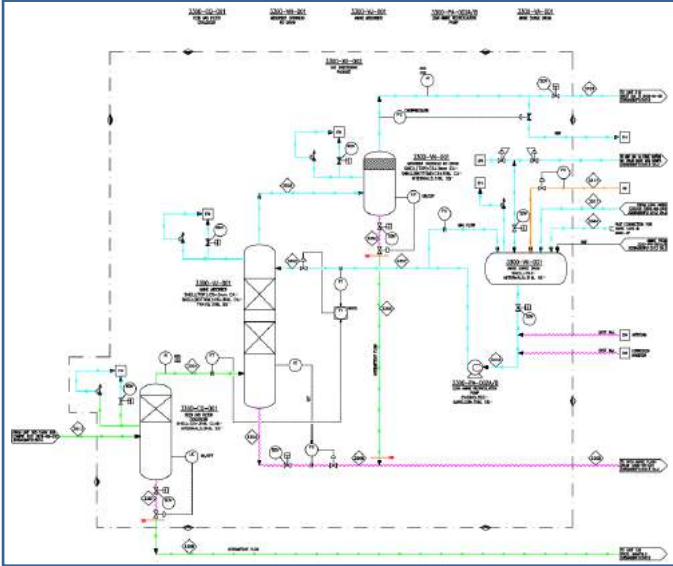

Fig. 6 - Material selection diagram for a gas dehydration unit

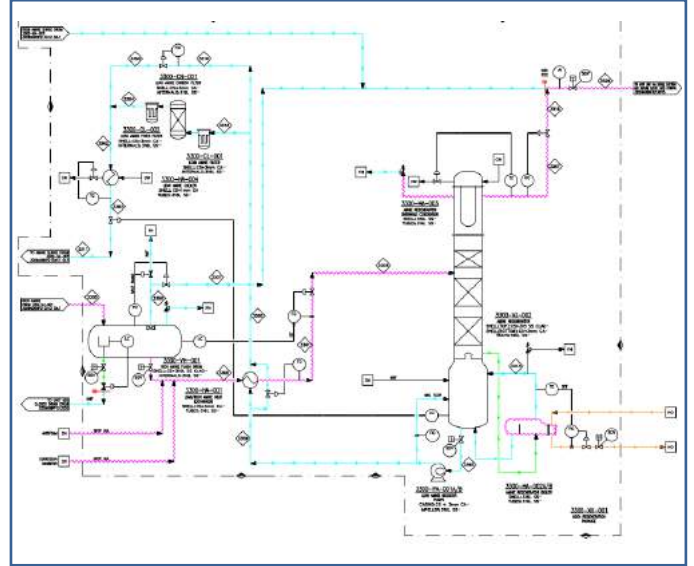

Fig. 7 - Material selection diagram for an oil stabilization unit

Corrosion Control Methods

The state-of-the-art knowledge for corrosion prevention and control is incorporated into a number of approaches, techniques and material solutions which, if correctly selected, designed and applied, allow to mitigate and control the corrosion mechanisms and thus guarantee the integrity of the assets during the whole project execution, at the right time, at the right place and with cost effectiveness. The main techniques are:

- Corrosion allowance
- Corrosion Resistant Alloys (CRA)
- Composite materials (GRE/GRP)
- Fluid treatment with chemicals: corrosion inhibitors, glycol, biocides, O₂ & H₂S scavenger
- Lining (mechanical bonding) or cladding (metallurgical bonding)
- Internal organic coatings and linings
- Internal cathodic protection
- External coatings and cathodic protection.

Requirements For Sour Service

In presence of H₂S in the fluid the risk of sulphide stress cracking is prevented by selecting Sour Service Grades materials in compliance with ISO 15156/NACE MR0175 and by appropriate testing.

For carbon and low alloy steels, the severity of the sour environment is assessed with reference to the Sulphide Stress Cracking (SSC) regions while for corrosion resistant alloys (Fig. 8) reference is made to threshold values of the influencing parameters.



Fig. 8 - External view of a petrochemical plant

Chemical Treatment Philosophy

The injection of chemicals is often essential to ensure the applicability of carbon steel as well as to control relevant corrosion issues. The purpose of the chemical treatment philosophy is to provide guidelines, at design stage, for the following aspects:

- To define the actual need for the use of chemicals
- To define the required mode of injection (continuous vs. batch)
- To identify the most suitable chemical injection points
- To roughly estimate the required dosage of each chemical.

Corrosion Monitoring Specification

Corrosion monitoring is used to control corrosion along the operating life of the assets and to optimize the injection of chemicals. The corrosion monitoring specification highlights the following:

- The types of probes to be installed (corrosion coupons, electrical resistance probes, sand probes etc.)
- The total number of devices to be installed
- The most suitable locations for the installation of the probes
- The retrieval intervals
- The data analysis and reporting requirements.

Coating & Painting Specification

Coating & painting specification is a project specific document and defines the surface preparation requirements as well as the coating cycles for pipelines, piping and equipment (Fig. 9).

The testing requirements are also included for qualification and production stages based on international normative such as Norsok, DNV, ISO and company technical standards.



Fig. 9 - Detail of stored coated pipes

Corrosion Management Manual

The Corrosion Management Manual is the document, issued in the development phase of a project and then maintained and updated during the operation phases, which illustrates the corrosion management process along the life of the project.

The Corrosion Management Manual identifies the key activities for corrosion control and the framework to mitigate and monitor corrosion mechanisms which may occur; it provides a reference document for field corrosion personnel, including all the necessary information to ensure an appropriate understanding and implementation of the corrosion management policy during the different phases of the project, and particularly operation.

Material Selection & Corrosion Management for other Industrial Sectors

Based on the extensive experience of Cescor, our technical capabilities in the areas of material selection and corrosion management can be transferred and adopted for other industrial sectors including renewables such as offshore wind farms as well as for other infrastructures (reinforced concrete, water transportation, heat exchangers, etc.).

Cescor Srl

Via Maniago 12
20134 Milano - Italy

 www.cescor.it
 info@cescor.it
 +39 02 26412538

Cescor UK Ltd.

Gable House
18-24 Turnham Green Terrace
Chiswick, London W4 1QP - U.K.

 www.cescor.co.uk
 info@cescor.co.uk
 +44 (0) 20 8996 5111

